



BRAKE NUMBER 93040 SERVICE NOTES

SHEET 1 OF 1

ECO: 32246 REV: Y

THIS MULTI-DISC BRAKE IS A HYDRAULICALLY APPLIED SPRING RELEASED BRAKE. HYDRAULIC PRESSURE IS REQUIRED TO APPLY THE BRAKE FOR SERVICE. NORMAL OPERATION IS TO HAVE THE BRAKE OFF WITHOUT HYDRAULIC INPUT.

CAUTION:

FOR CORRECT OPERATION, THE HYDRAULIC PRESSURE MUST FALL TO ZERO TO ALLOW "FREE-RUNNING CONDITION". ANY BACK PRESSURE WILL RESULT IN A PARTIALLY APPLIED BRAKE. IN THIS CONDITION VEHICLE MOTION MAY CAUSE PREMATURE LINING WEAR, WHICH MAY RESULT IN A HAZARDOUS CONDITION.

INITIAL INSTALLATION INFORMATION:

1. ASSEMBLE BRAKE TO VEHICLE. SLIDE BRAKE OVER AXLE SPLINE, ALIGNING THE INTERNAL SPLINES OF THE BRAKE WITH THE SPLINES OF THE AXLE. POSITION BRAKE SO THAT THE BRAKE LINE FITTINGS ARE AT THE TOP OF THE BRAKE FOR BLEEDING PURPOSES.
2. PLACE THE MOUNTING BRACKETS ON THE INBOARD SIDE OF THE AXLE MOUNTING FLANGE. INSERT FOUR LUBRICATED 5/16-18 HEX HEAD BOLTS (GRADE 8) THROUGH THE MOUNTING BRACKETS, THROUGH THE AXLE MOUNTING FLANGE, AND INTO THE THREADED HOLES IN THE BRAKE. TORQUE HEX HEAD BOLTS TO 220-245 IN-LB (25-28 Nm).
3. ATTACH BRAKE LINE TO BRAKE. WITH BRAKE IN POSITION, CONNECT INLET BRAKE LINE. BRAKE INLET IS M10 X 1.0 BANJO BOLT AND PORT. USE BRASS WASHERS ON BOTH SIDES OF BANJO BOLT HOSE FOR PROPER SEALING.
4. BLEED BRAKE TO ELIMINATE ANY AIR IN THE BRAKE LINES.
5. FOR WHEEL ASSEMBLY, FOLLOW VEHICLE MANUFACTURER'S INSTRUCTIONS.
6. GREASE OUTBOARD SEALS BY INSTALLING GREASE INTO FRONT GREASE FITTING UNTIL IT RUNS OUT THE FRONT SHAFT SEAL. TURN HUB 1/4 TURN AND REPEAT GREASING THREE TIMES.

BRAKE DISASSEMBLY INFORMATION:

1. REMOVE BRAKE FROM VEHICLE.
2. SPECIALIZED EQUIPMENT AND GAGING IS NEEDED TO PROPERLY REBUILD THE BRAKE.
IF THE BRAKE IS WORN OR DAMAGED, REPLACE BRAKE.

OIL FILL PROCEDURE:

ADD 240 ± 10 mL AW68 OF HYDRAULIC OIL.

PRESSED STUD REPLACEMENT PROCEDURE:

NOTE: THIS PROCEDURE IS FOR BRAKES WITH A 2 PIECE FLANGED HUB ONLY.

1. REMOVE (4) 3/8-24 UNF HEX BOLTS HOLDING FLANGE TO MAIN HUB.
2. REMOVE FLANGE.
3. PRESS OUT AND REPLACE STUDS AS NEEDED.
4. REPLACE FLANGE O-RING AND REGREASE.
5. BEFORE REINSTALLING FLANGE VERIFY THAT BOTH MOUNTING SURFACES AND INSIDE OF HUB IS CLEAN AND FREE OF DIRT AND DEBRIS.
6. REINSTALL FLANGE AND TIGHTEN 3/8-24 UNF HEX BOLTS TO 55-60 FT-LBS [75-81 Nm]. BOLTS TO BE DRY.

SERVICE KIT INFORMATION

STUD KIT	PK.2686	(FOR 2 PIECE HUB) INCLUDES: PRESS FIT STUDS, AND O-RING.
STUD KIT	PK.2233	(FOR 1 PIECE HUB) INCLUDES: THREADED STUDS.
FLANGE KIT	107509	INCLUDES: FLANGE ASSEMBLY, BOLTS, AND WASHERS,



BRAKE No. 93040 CUTAWAY VIEW

ECO 32246 REV Y

ITEM	PART NUMBER	PART NAME	QTY
1	92703	POWER PLATE	1
2	33425	BLEEDER SCREW	1
3	92573	BLEEDER SCREW CAP	1
4	92596	O-RING	1
5	92701	HOUSING	1
6	86935	GREASE FITTING	1
7	92572	GREASE FITTING CAP	1
8	106686	FLANGE - 4 BOLT	1
9	106954	WHEEL STUD	4
10	70950	PROTECTIVE CAP	4
11	107287	HEX BOLT	4
12	106738	O-RING	1
13	106688	HUB	1
14	92351	OIL SEAL	1
15	92350	OIL SEAL	1
16	92725	TAPERED ROLLER BEARING (CONE)	1
17	92724	TAPERED ROLLER BEARING (CUP)	1
18	75072	STATIONARY DISC	4
19	90730	ROTATING DISC	3
20	92563	HEX HEAD O-RING BOSS PLUG	2
21	91035	O-RING	1
22	92706	PISTON	1
23	91930	O-RING	1
24	93664	C-RING	1
25	92870	BALL BEARING	1
26	92547	O-RING	1
27	92402	OIL SEAL	1
28	90767	HEX BOLT	4
29	90725	MOUNTING BRACKET	2
30	26930	PROTECTIVE PLUG	1
31	92776	HEX BOLT	6
32	73464	WASHER	6
33	32201	O-RING	6
34	90757	TORQUE PIN	4
35	93025	COMPRESSION SPRING	2
36	93665	RETAINING RING	1
37	93754.03	THRUST WASHER	*
38	93754.04	THRUST WASHER	*
39	93754.05	THRUST WASHER	*
40	107291	WASHER- LOCKING	4
41	107325	DOWEL PIN	2
42	98663	CAP	2

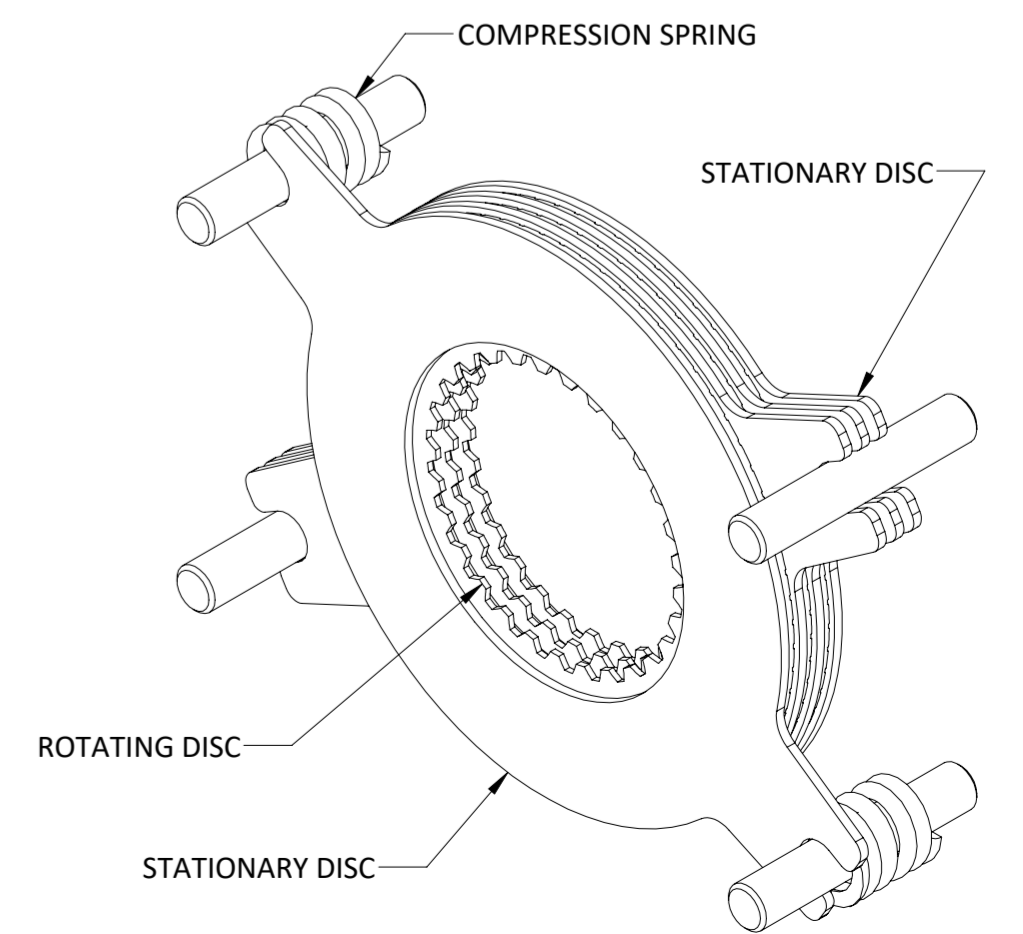
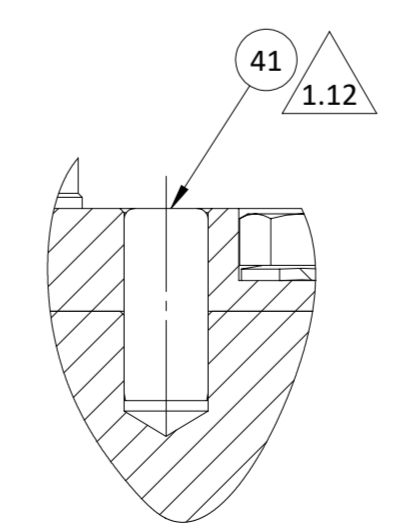
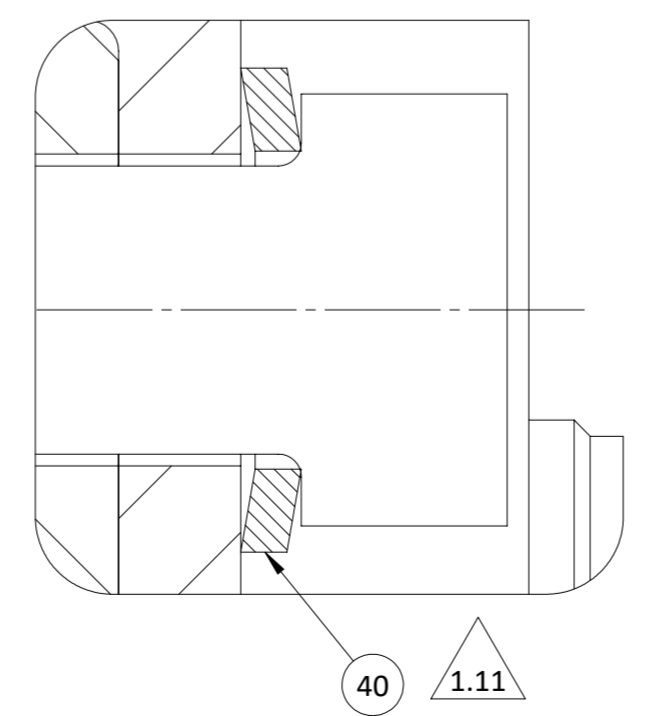
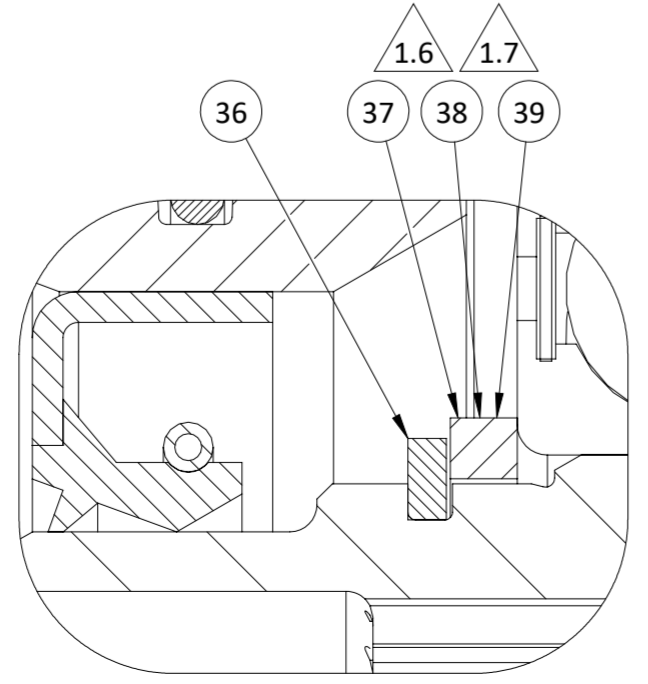
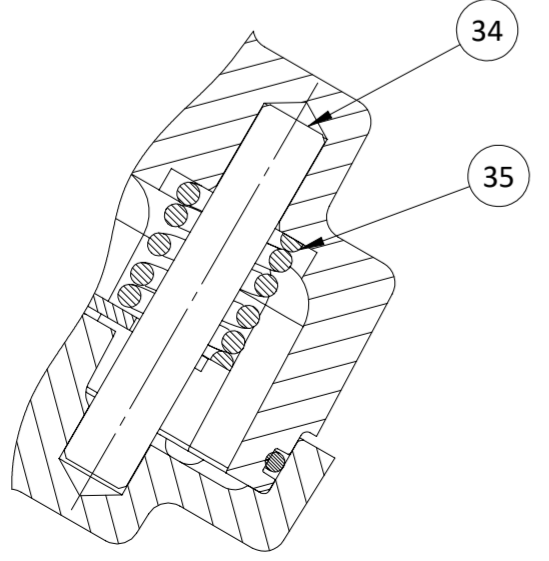
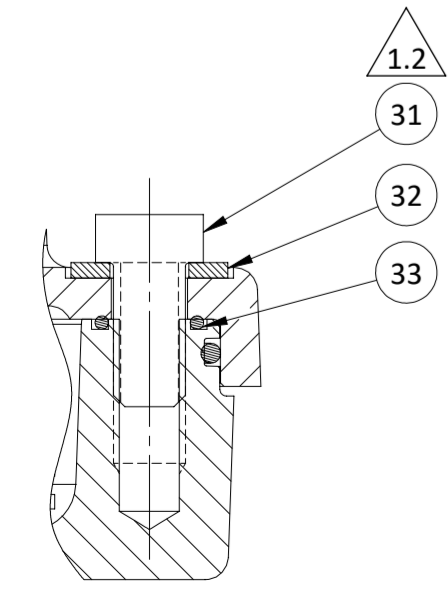
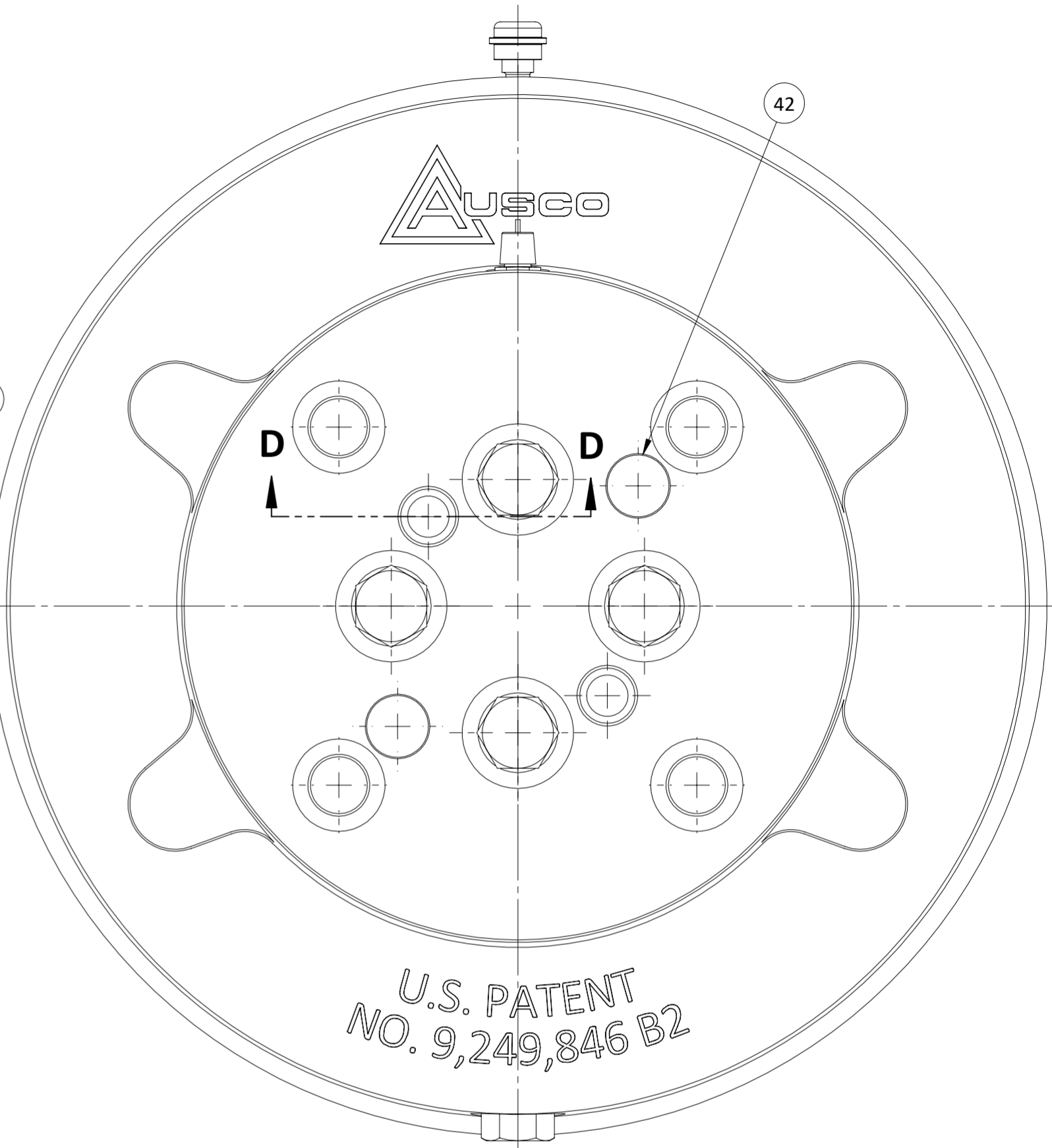
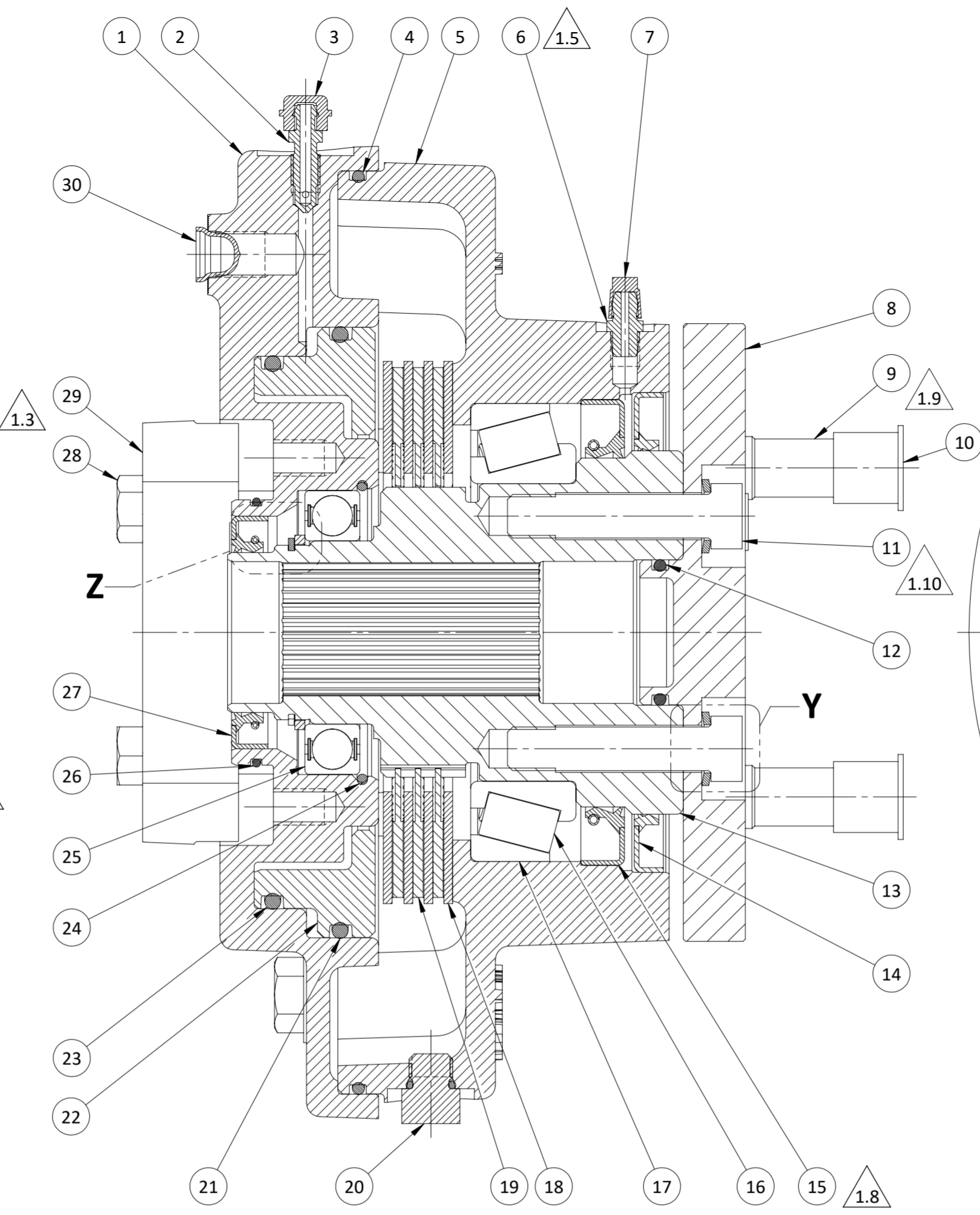
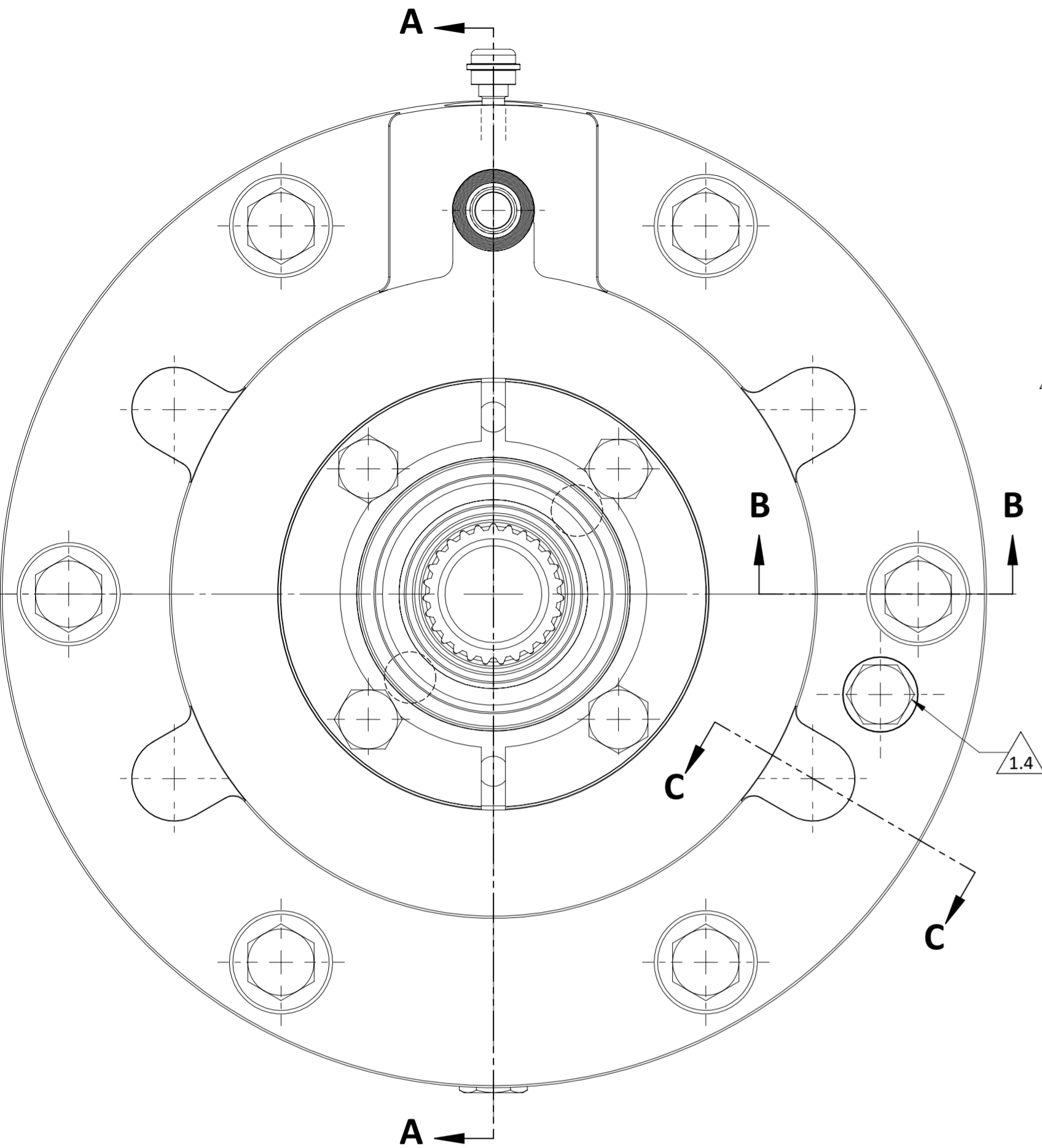

SECTION B-B

SECTION C-C

DETAIL Z
SCALE 4 : 1

DETAIL Y
SCALE 4 : 1

SECTION D-D **V3**

STACK ORIENTATION VIEW
NO SCALE