

THE FAILSAFE BRAKE IS SPRING LOADED TO APPLY THE BRAKE AND HYDRAULIC PRESSURE IS REQUIRED TO RELEASE OR "HOLD OFF" THE BRAKE. NORMAL OPERATION IS TO HAVE THE BRAKE PRESSURIZED IN THE RELEASED POSITION WITH THE VEHICLE HYDRAULIC SYSTEM RUNNING. ANY FUNCTION WHICH REDUCES THE HYDRAULIC SYSTEM PRESSURE BELOW THE RELEASE PRESSURE OF THE BRAKE WILL CAUSE THE BRAKE TO BE APPLIED.

INSTALLATION INFORMATION:

1. REMOVE NUT AND WASHER FROM THE SHAFT.
2. INSTALL YOKE, WASHER AND NUT. TORQUE NUT TO 275-325 FT-LBS [373-441 Nm].
3. MOVE BRAKE INTO POSITION AND ALIGN MOUNTING BOLT HOLES AND INSERT FOUR UNLUBRICATED 16 mm BOLTS OR FOUR UNLUBRICATED 5/8 INCH BOLTS THROUGH HOLES IN EACH MOUNTING FOOT. TIGHTEN ALTERNATELY UNTIL SNUG. TORQUE BOLTS AS FOLLOWS:

FOR 5/8" GRADE 5 BOLTS: 150-165 FT-LBS [203-224 Nm]
 FOR 5/8" GRADE 8 BOLTS: 215-235 FT-LBS [292-319 Nm]
 FOR 16mm CLASS 10.9 BOLTS: 230-255 FT-LBS [312-346 Nm]

4. SLIDE YOKE OVER SHAFT.
5. CONNECT VEHICLE DRIVELINE TO BRAKE YOKES.
6. CONNECT HYDRAULIC SUPPLY LINE TO POWER PLATE INLET
7. REMOVE FILL LEVEL PLUG FROM SIDE OF BRAKE. FILL BRAKE CAVITY WITH MOBIL DTE-26 OIL UNTIL OIL RUNS OUT OF PORT. REPLACE PLUG AND TIGHTEN.

BRAKE DISASSEMBLY INFORMATION:

1. REMOVE BRAKE FROM MOUNTING POSITION AND REMOVE YOKES.
2. POSITION BRAKE WITH POWER PLATE UP, THE SIDE WITH MOUNTING FEET.
3. REMOVE ASSEMBLY BOLTS ALTERNATELY KEEPING POWER PLATE PARALLEL TO THE HOUSING TO PREVENT DAMAGE TO BEARINGS. USE EXTREME CAUTION: SPRINGS CAN CAUSE POWER PLATE ASSEMBLY TO POP OFF HOUSING.
4. AFTER THE ASSEMBLY BOLTS HAVE BEEN REMOVED, REMOVE POWER PLATE ASSEMBLY FROM BRAKE.
5. REMOVE SHAFT AND DISC STACK FROM THE BRAKE. IF THE STACK IS TO BE SERVICED, USE A SHOP PRESS. REMOVE THE BEARING CONES FROM SHAFT.
6. REMOVE PRIMARY PLATE, SPRINGS AND SPRING RETAINER FROM HOUSING SPRING POCKET.
7. REMOVE PISTON FROM POWER PLATE BY INTRODUCING LOW-PRESSURE AIR, 15 PSI, INTO HYDRAULIC INLET. MAKE SURE THE PISTON IS DIRECTED AWAY FROM THE OPERATOR. REMOVE O-RINGS FROM THE O.D. AND I.D. OF THE GROOVE OF THE PISTON.

NOTE: IF THE BEARING AND/OR SEALS ARE REMOVED, BOTH MUST BE REPLACED. SEAL CAN BE REMOVED BY PRYING IT OUT WITH AN APPROPRIATE TOOL. CARE MUST BE TAKEN NOT TO DAMAGE THE BORE.

ASSEMBLY INFORMATION:

IMPORTANT: THERE MAY BE MORE PARTS IN A SERVICE KIT THAN YOUR BRAKE REQUIRES. CHECK THE PARTS LIST CAREFULLY FOR THE EXACT QUANTITY. SPACE THE SPRINGS AS SHOWN ON THE SPRING ORIENTATION.

USE THE REVERSE OF THE DISASSEMBLY PROCEDURE WITH THE FOLLOWING NOTES AND ADDITIONS:

1. WORN OR DAMAGED O-RINGS MUST BE REPLACED PRIOR TO REASSEMBLY.
2. CYLINDER OF THE POWERPLATE, PISTON, AND O-RINGS MUST BE PRE-LUBED WITH SYSTEM HYDRAULIC FLUID PRIOR TO REASSEMBLY.
3. PISTON ASSEMBLY:
 ASSEMBLE PISTON INTO POWER PLATE USING A SHOP PRESS. TAKE CARE NOT TO DAMAGE THE O-RINGS. VISUALLY ALIGN THE CENTER OF THE CUTOUTS IN THE PISTON WITH THE TORQUE PIN HOLES IN THE POWER PLATE.
 CAUTION: THE DEPTH THE PISTON IS INSTALLED INTO THE POWER PLATE IS CRITICAL. THE SURFACE OF THE PISTON AT THE CUTOUTS MUST BE FLUSH TO 0.120 [3.05mm] BELOW THE SURFACE OF THE POWER PLATE OR PISTON WILL COCK RESULTING IN A COMPLETE LOSS OF BRAKING.
4. BEARING ASSEMBLY:
 USING A SHOP PRESS, INSTALL ONE CONE ON THE SHAFT. BEARING MUST BE SEATED TIGHT AGAINST THE STOP. PRESS ONLY ON THE INNER RACE OF THE BEARING CONE, NOT ON THE ROLLERS. INSTALL THE STATOR AND ROTATING DISCS ON THE SHAFT. NOTE THE ORDER OF THE DISCS IN RELATIONSHIP TO THE ENDS OF THE SHAFT. PRESS THE OTHER CONE ONTO THE SHAFT OBSERVING THE PRECEDING CAUTIONS. SEE CUTAWAY VIEW FOR BEARING ORIENTATION.
5. BRAKE ASSEMBLY:
 INSTALL PARTS IN REVERSE ORDER OF DISASSEMBLY LEAVING THE SHAFT SEALS TO LAST. RELEASE THE BRAKE WITH 300 PSI [21 BAR] AND MEASURE THE TORQUE TO ROTATE THE SHAFT. THE FREE ROLLING TORQUE OF THE BRAKE SHAFT IS AN INDICATION OF BEARING SEATING AND FIT. THE ROLLING TORQUE MUST BE 20 IN-LBS [2.2 Nm] MAX. IF IT DOES NOT MEET SPECIFICATION, CHECK THAT THE BEARINGS ARE WELL SEATED. SEE CUTAWAY VIEW FOR SEAL ORIENTATION.
6. LIP SEAL ASSEMBLY:
 AFTER THE BRAKE IS ASSEMBLED, INSTALL THE SHAFT SEALS WITH CAUTION NOT TO CUT THE SEAL LIPS ON THE SHAFT SPLINES. THE SEAL IS INSTALLED WITH TWIN LIPS FACING OUTWARDS, AWAY FROM THE BRAKE. THE SINGLE LIP WILL FACE INWARDS.

SERVICE KIT INFORMATION:

BEARING KIT: PK.1497 - INCLUDES SEALS, RETAINING RINGS, AND BEARINGS.

STACK KIT: PK.1496 - INCLUDES TORQUE PINS, COMPRESSION SPRINGS, PRIMARY, STATIONARY, AND ROTATING DISCS.

O-RING KIT: PK.1495 - INCLUDES O-RINGS, BACKUP RINGS, AND INTERNAL GASKET.

ITEM	PART	DESCRIPTION	QTY
1	80184	HOUSING	1
2	74523	SPRING RETAINER	1
3	36359	COMPRESSION SPRING	46
4	74526	DISC-PRIMARY	1
5	89568	DISC ROTATING	5
6	74529	DISC STATIONARY	5
7	74532	GASKET	1
8	79800	POWER PLATE	1
9	74538	O-RING	1
10	74556	PISTON	1
11	74558	O-RING	1
12	75219	TAPER ROLLER BEARING (CUP)	2
13	75218	TAPER ROLLER BEARING (CONE)	2
14	74921	NUT	1
15	75411	SPLINED SHAFT	1
16	74958	WASHER	1
17	75409	WASHER	1
18	80991	LIP SEAL	2
19	74539	BOLT-HEX FLANGED	8
20	37518	PIN-TORQUE	2
21	35553	PLUG-HEX HEAD	2
22	36673	PROTECTIVE PLUG	1
23	37176	VALVE PRESSURE RELIEF	1
24	75970	CAUTION TAG	1
25	86051	SHIM	*
26	80392	SHIM	*

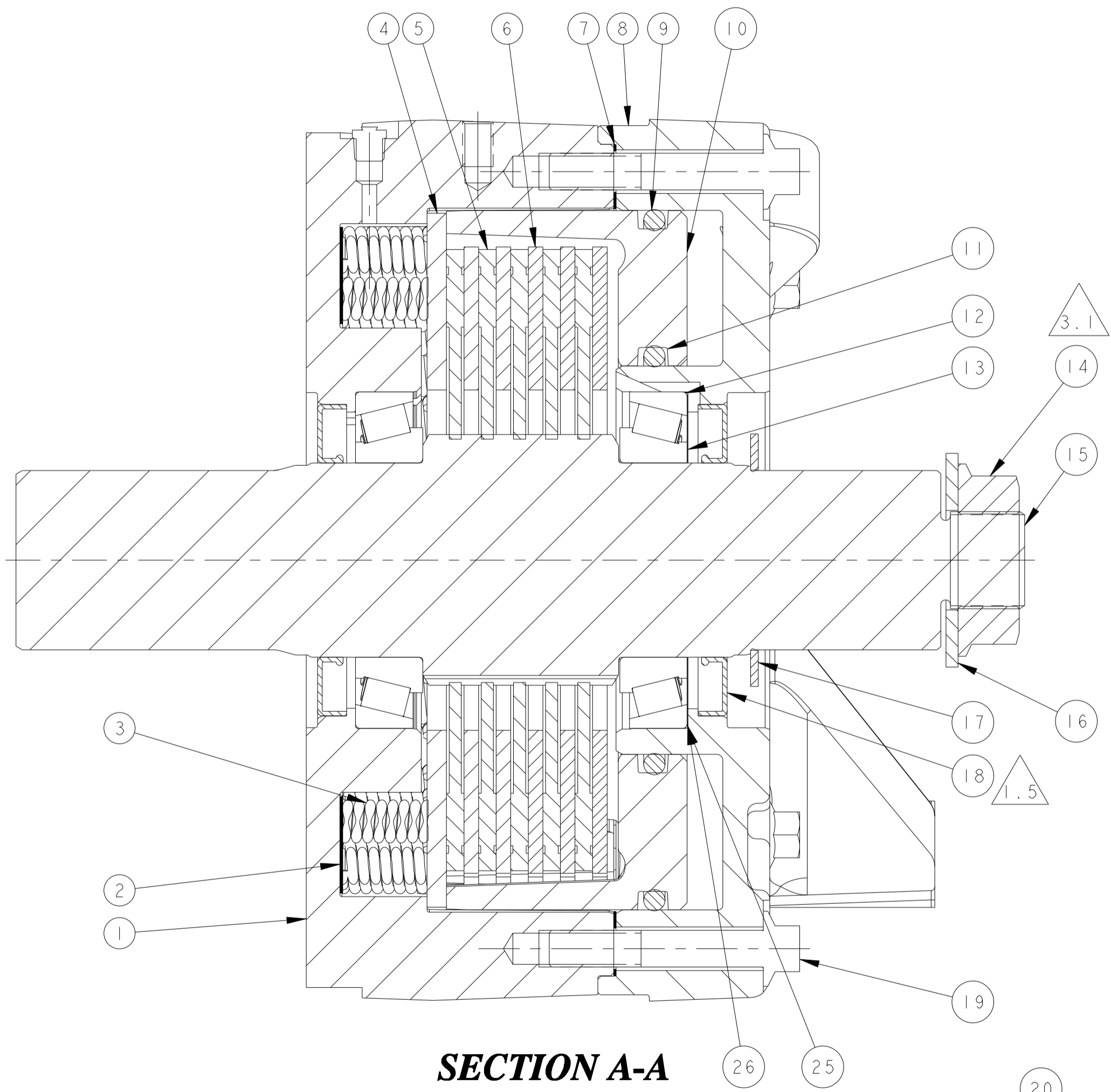

SECTION A-A

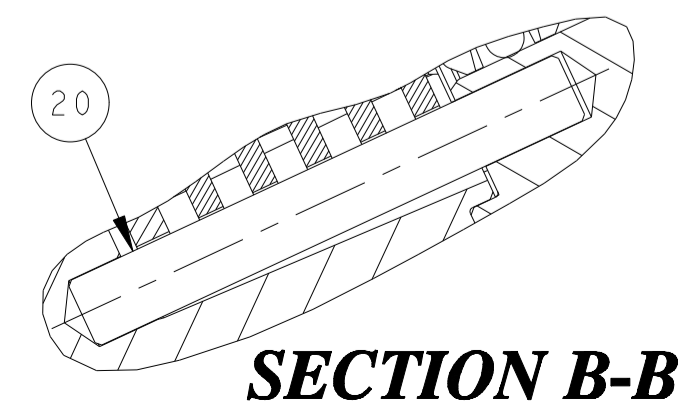

SECTION B-B

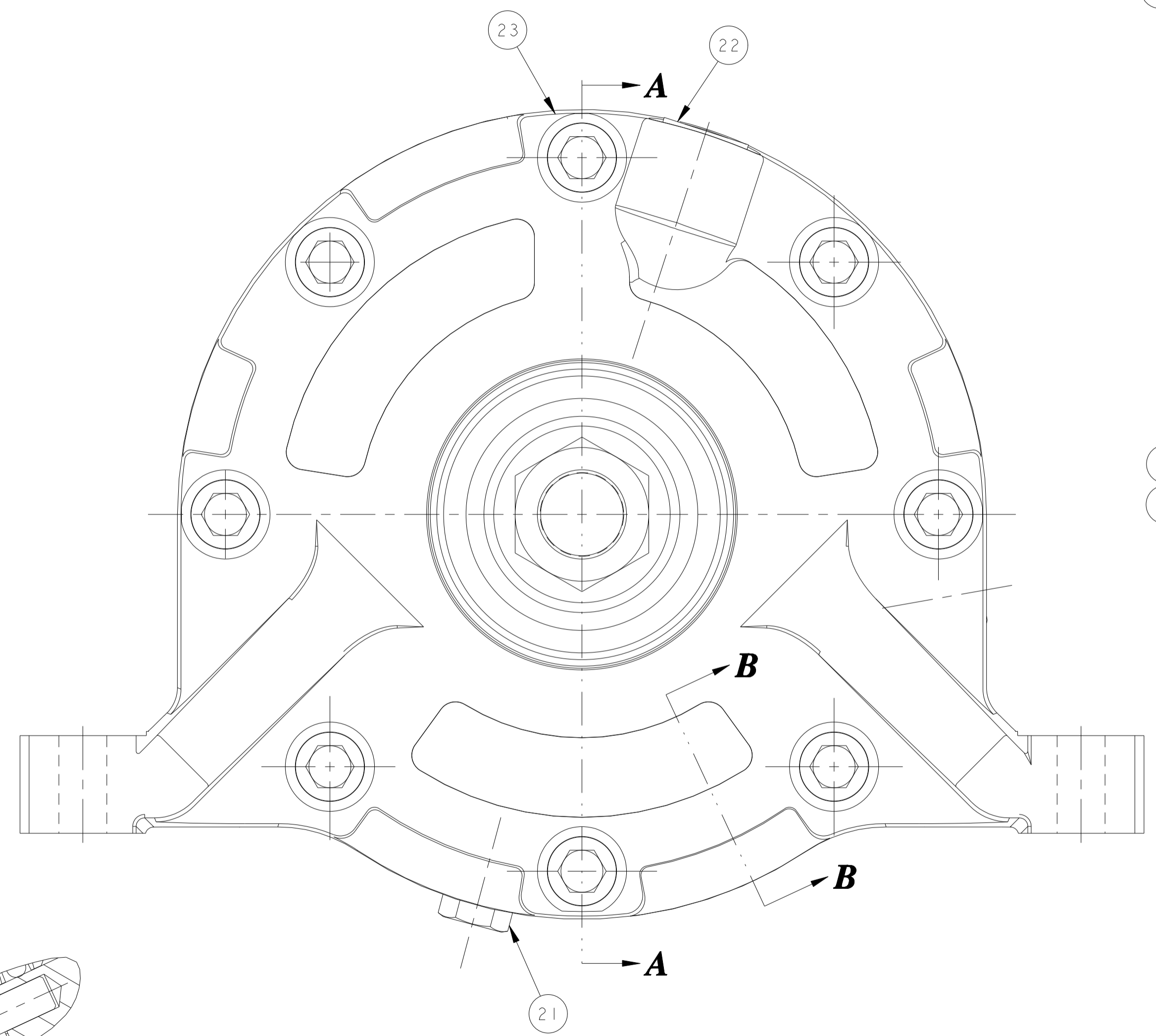

P2

P5

P6

GENERAL ASSEMBLY VIEW

THIS DRAWING PROVIDES GENERAL GUIDELINES AND ASSEMBLY INFORMATION ON AUSCO MULTI-DISC BRAKES. CONFIGURATION OF BRAKES VARIES FROM MODEL TO MODEL. CONSULT YOUR BRAKES SERVICE NOTES, BILL OF MATERIAL, AND CUTAWAY VIEW FOR EXACT DETAILS.

